

UPPER WING ASSEMBLY
SCALE: 3"=1'-0"

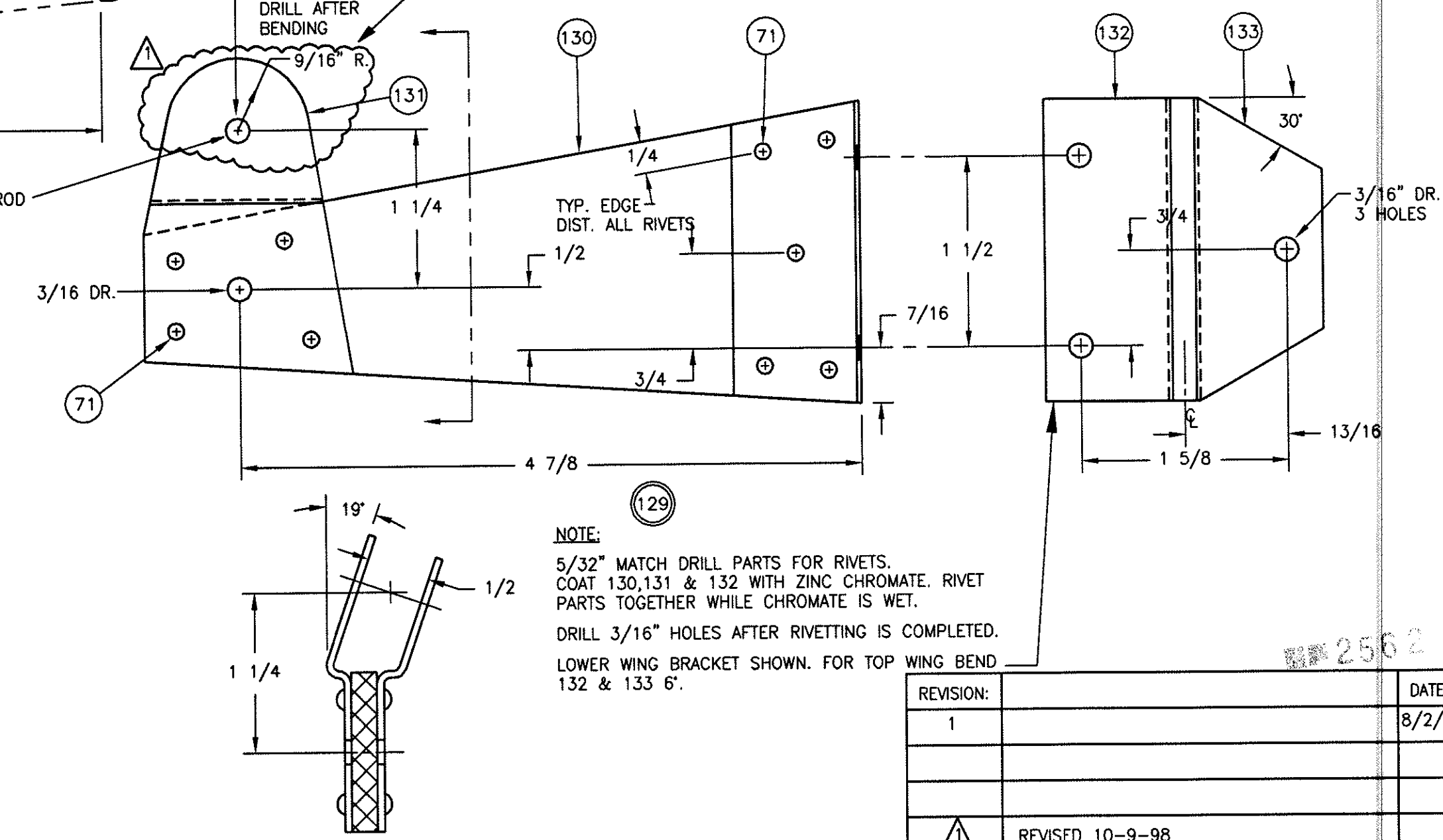
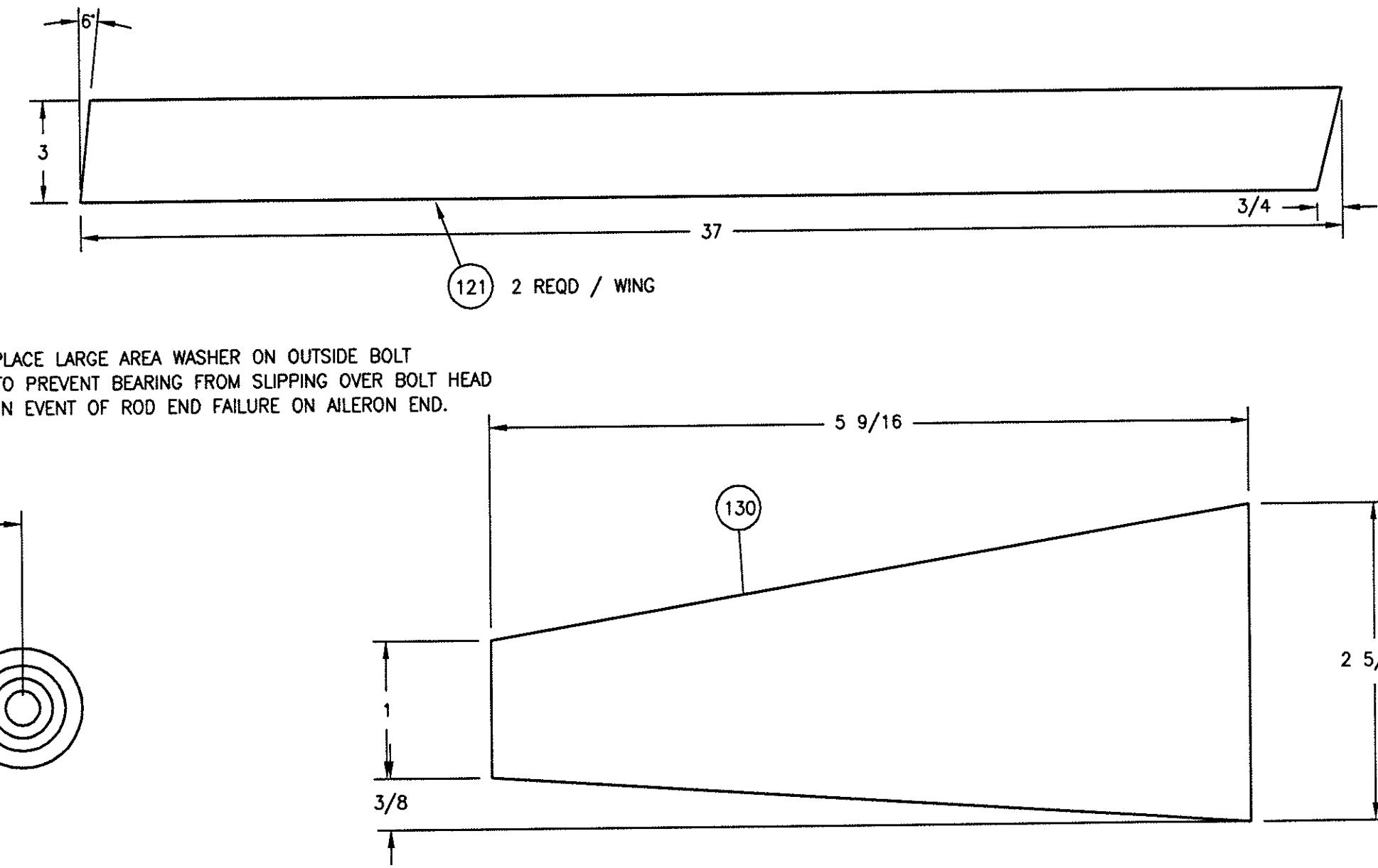
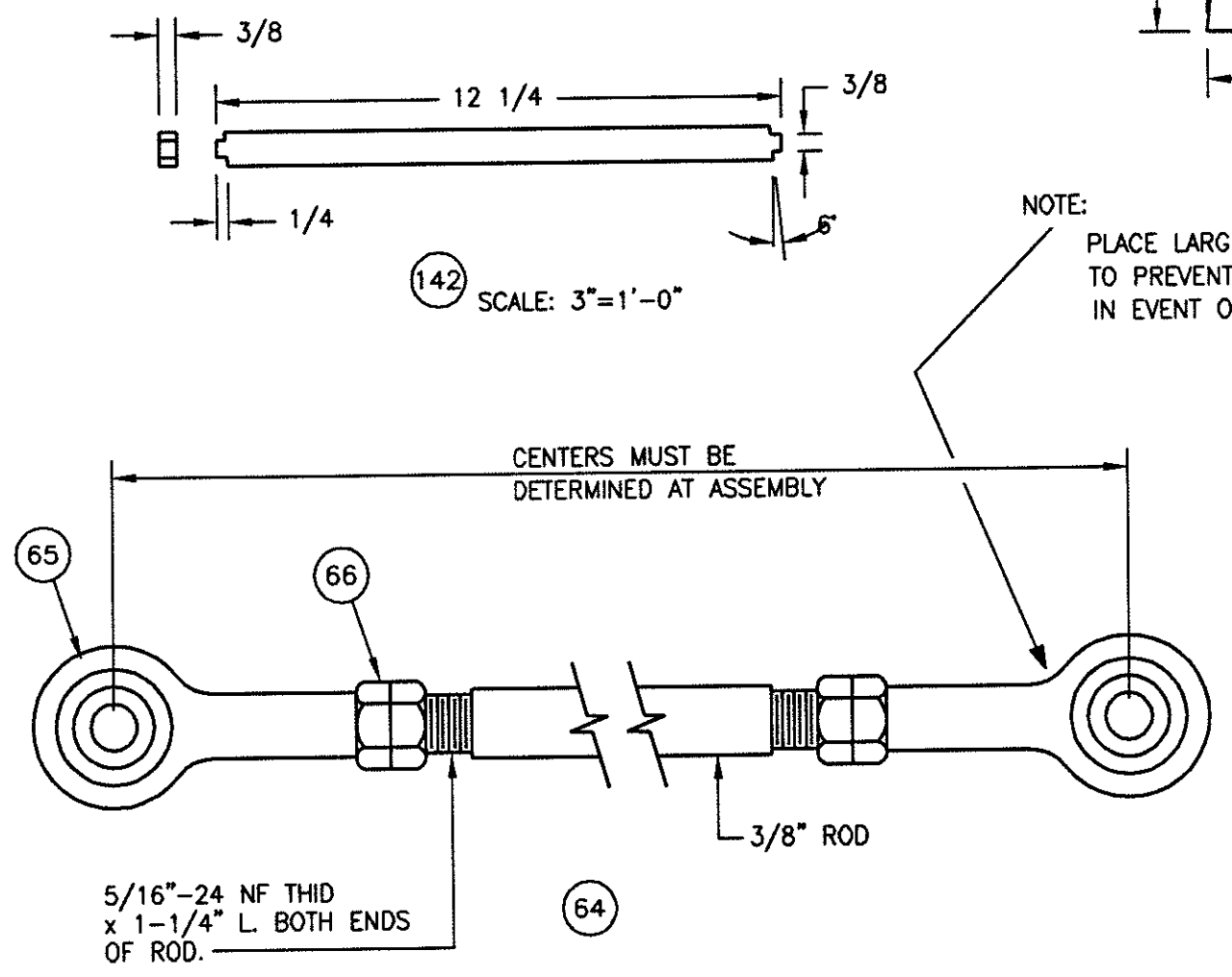
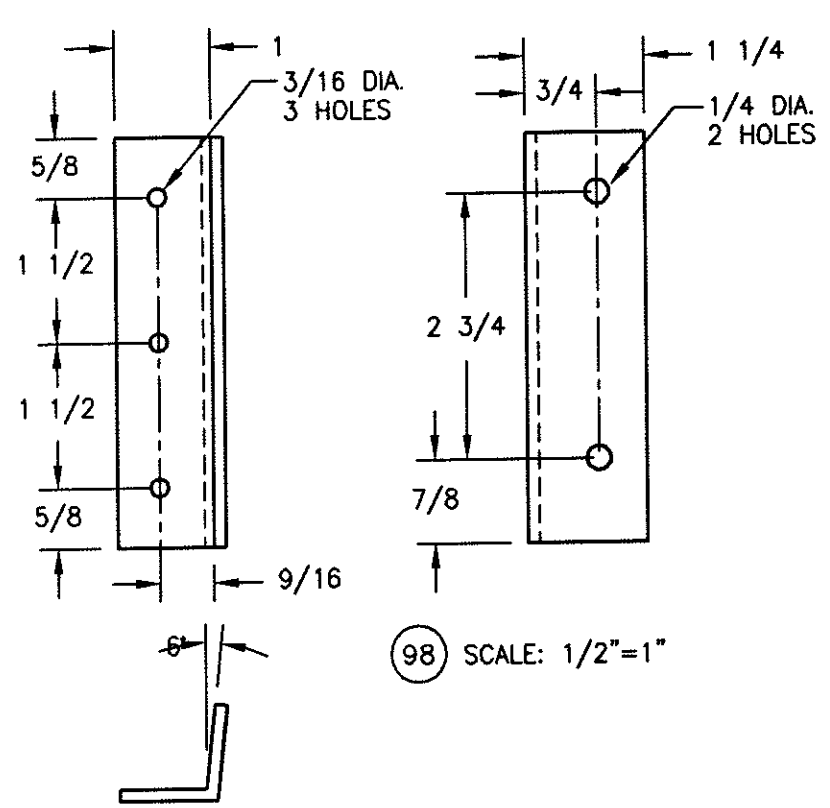

REVISION:	DATE:
1	8/2/99
REVISED 10-9-98	
Sheet No. 3 Starduster Too Model SA300	
DRAWN BY: 6/1/98	
DESIGN BY: RH WING UPPER	
129 Chuck Yeager Way, Oroville, CA 95965	
PHONE: 530-534-7434 FAX: 530-534-7451	
WEB SITE: www.starduster.com	

PRODUCT NAMES AND PLANS ARE COPYRIGHTED ALL RIGHTS RESERVED-PLANS PURCHASER IS AUTHORIZED TO BUILD ONE AIRPLANE ONLY-UNAUTHORIZED REPRODUCTION, OR COMMERCIAL USE OF THESE PLANS EXPRESSLY PROHIBITED.